



MACHINE TOOLS

Frontal attachments & Buckets for loaders

Located in Ostrołęka, the heart of the Kurpie region, **Hydro-Instal Attachments** stands as a testament to genuine craftsmanship. Our dedication to quality ensures you can **always rely on our products and services**.

Hydro-Instal Ostrołęka team

Hydro-Instal T.Sieruta B.Sieruta sp.j.
ul. Bohaterów Westerplatte 11
07-410 Ostrołęka
Poland
EU VAT ID: PL7581556948



sieruta.com

info@sieruta.com



Loader buckets

FGP - FRONT GENERAL PURPOSE LOADER BUCKET



Model	Machine class [t]	Width [mm]	Tip radius [mm]
FGP-60	2 - 6	1900 - 2100	900
FGP-160	12 - 14	2500 - 2700	1158
FGP-190	14 - 17	2600 - 2800	1216
FGP-230	17 - 20	2800 - 3000	1372
FGP-260	20 - 24	3000 - 3200	1500

A jack-of-all-trades for your loader, the Front General Purpose Loader Bucket tackles various loose materials for efficient loading, unloading, and stockpiling.

LSF - LOADER STONE FORKS



Model	Machine class [t]	Width [mm]	Weight [kg]
LSF-60	2 - 6	1480	241
LSF-100	6 - 10	2030	330
LSF-160	10 - 16	2464	896

Loader Stone Forks are tough attachments designed to securely pick up, transport, and handle rocks and other heavy materials.

FLB - FRONT LEVELLING BUCKET FOR LOADERS



Model	Machine class [t]	Width [mm]
FLB-180	2 - 4	1800
FLB-200	4 - 6	2000
FLB-220	6 - 9	2200
FLB-240	9 - 12	2400
FLB-260	12 - 14	2600
FLB-280	14 - 17	2800
FLB-300	17 - 20	3000

Achieve precision grading on your next project. Front Levelling Buckets for loaders deliver exceptional results.

Founded in 1996

Manufacturing attachments since 2008

More than 45000 attachments delivered

Localised in Poland, 120 km from Warsaw capital & airport

Focus on quality & customer service



FGP FRONT GENERAL PURPOSE LOADER BUCKET

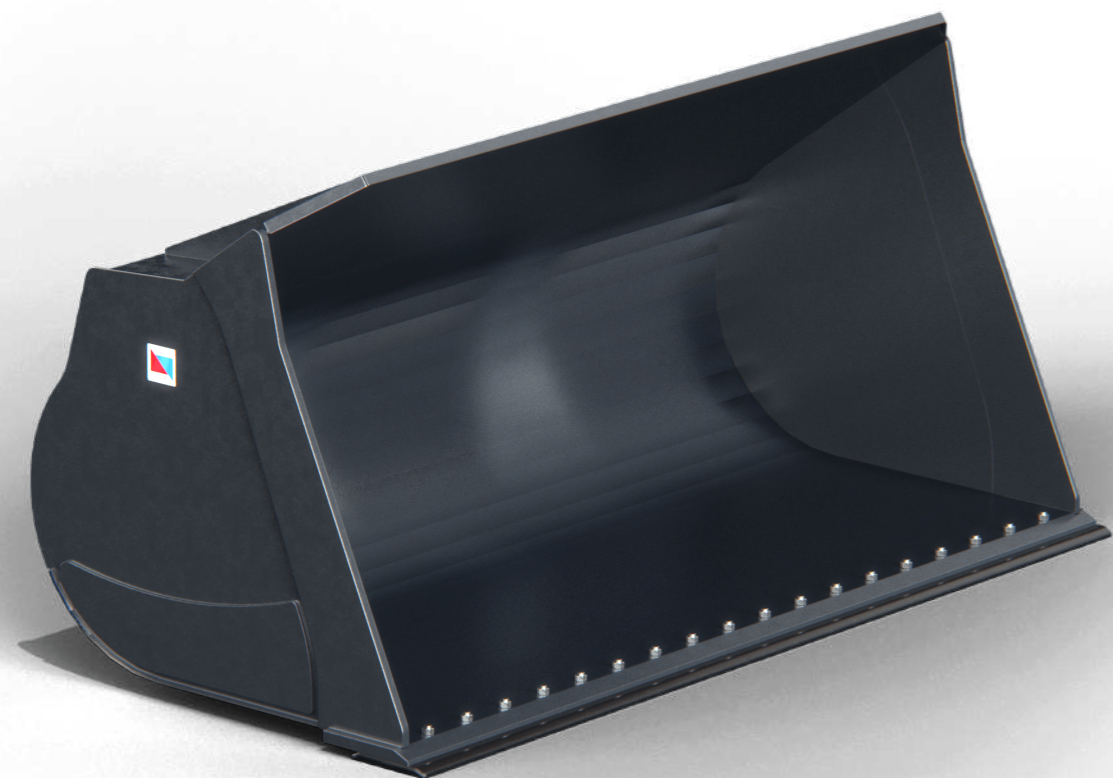

Maximize Loader Versatility. The Front General Purpose Loader Bucket tackles loading, digging & material handling for optimal machine performance on any job site.

Key Features:

- Optimized Design for Loading & Digging
- Durable Construction for Long Service Life
- Large Capacity for Maximized Productivity
- Fits Most Loader Models

The Front General Purpose Loader Bucket is ideal for:

- Loading & Transporting Loose Materials
- Light Digging & Excavation
- Site Cleanup & Debris Removal
- Landscaping & Construction Projects
- Versatile Material Handling

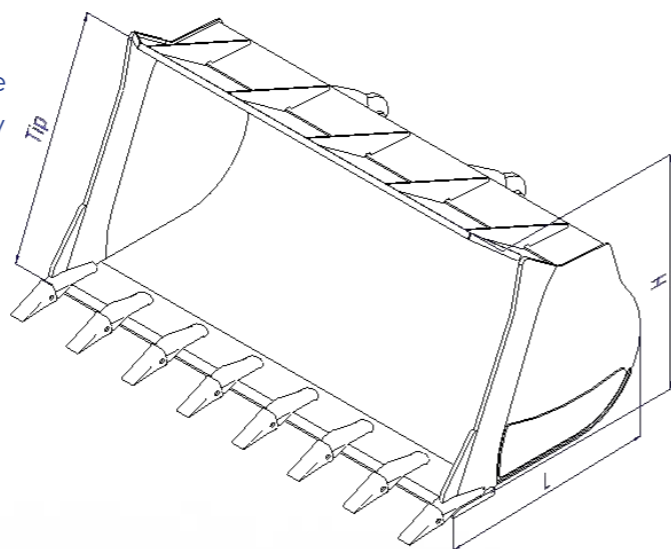

Equip your loader for success in diverse applications with the Front General Purpose Loader Bucket. This essential attachment delivers exceptional performance for a wide range of loading, digging, and material handling tasks, maximizing your machine's versatility and efficiency on any project.

Upgrade your loader's capabilities and conquer diverse tasks with the Front General Purpose Loader Bucket. **Contact us today to explore the perfect fit for your loader model!**

	FGP-60	FGP-160	FGP-190	FGP-230	FGP-260
Machine class [t]	2 - 6	12 - 14	14 - 17	17 - 20	20 - 24
L / H / Tip	912/966/900	1171/1242/1158	1230/1302/1216	1395/1471/1372	1524/1610/1500
Width [mm]	SAE / KG	SAE / KG	SAE / KG	SAE / KG	SAE / KG
1900	1045 / 320				
2000	1105 / 332				
2100	1160 / 345				
2500		2254 / 856			
2600		2350 / 882	2590 / 3520		
2700		2446 / 908	2696 / 3653		
2800			2802 / 3786	3544 / 1380	
2900				3680 / 1415	
3000				3815 / 1451	4507 / 1948
3100					4669 / 1993
3200					4830 / 2038

LSF LOADER STONE FORKS



Efficiently handle large rocks with the Loader Stone Forks. Strong steel rods conquer rock handling & clear rocky terrain, maximizing productivity.

Key features:

- Strong Steel Rods
- Optimized Spacing
- Durable Construction
- Fits Most Loader Models

The Loader Stone Forks are ideal for:

- Transporting large rocks, boulders, and debris
- Clearing rocky terrain and construction sites
- Landscaping projects requiring rock placement
- Streamlining rock handling operations in quarries and mines
- Any application demanding efficient and robust rock transportation

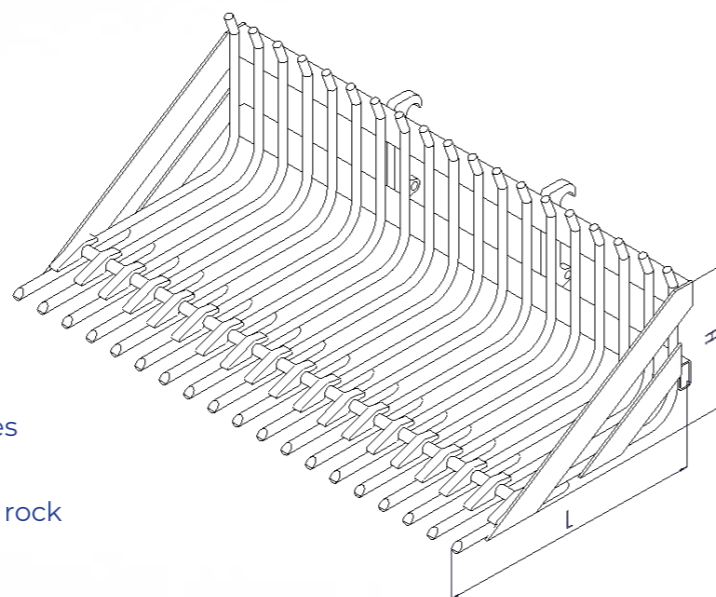

Equip your loader to conquer demanding rock handling tasks with the Loader Stone Forks. Constructed from high-strength steel rods, this attachment provides a robust solution for transporting large stones, boulders, and debris. The spaced design allows smaller materials like dirt and gravel to fall through, streamlining your workflow and maximizing efficiency in rocky environments.

Upgrade your loader's capabilities and conquer rock handling challenges with the Loader Stone Forks. **Contact us today to explore the perfect fit for your loader model!**

Model	Machine class [t]	Width [mm]	Weight [kg]	Length [mm]	Height [mm]
LSF-60	2 - 6	1480	241	1050	635
LSF-100	6 - 10	2030	330	1050	635
LSF-160	10 - 16	2464	896	1615	845

FLB FRONT LEVELLING BUCKET FOR LOADERS

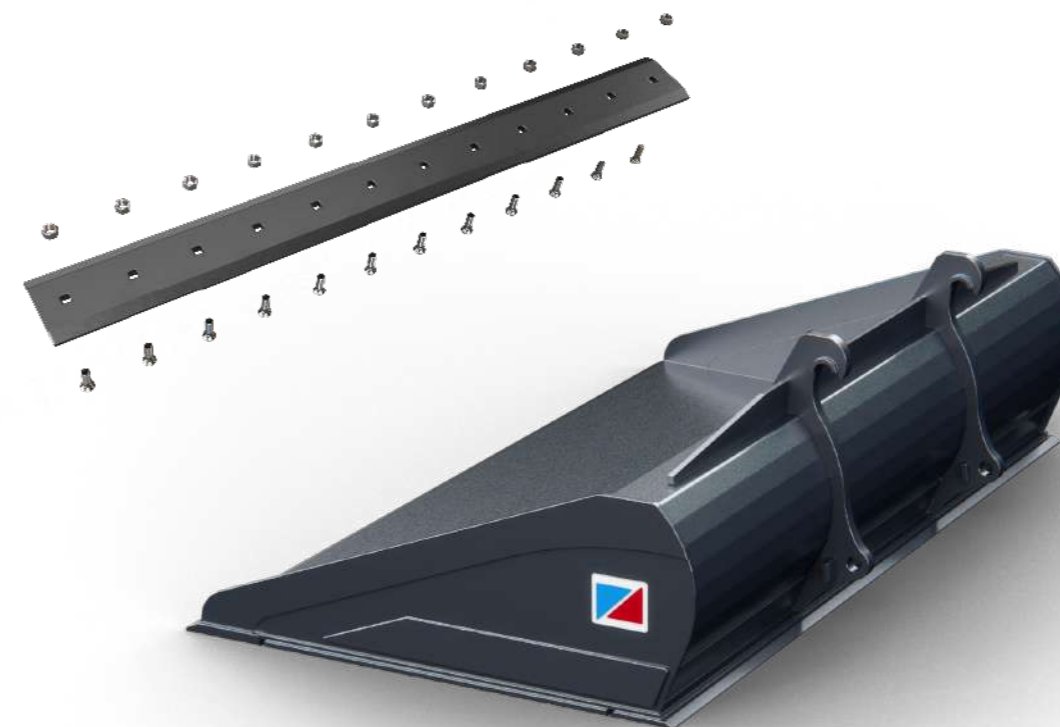

Achieve Precise Grading: The Front Leveling Bucket for loaders. Ideal for fine grading, backfilling, and material leveling tasks on any job site.

Key features:

- Optimized Design for Precision Grading
- Durable Construction for Long Service Life
- Exceptional Control for Streamlined Workflows
- Fits Most Loader Models

The Front Leveling Bucket is ideal for:

- Fine grading and leveling applications
- Backfilling trenches and foundations
- Landscaping projects requiring precise material placement
- Finishing touches on construction sites
- Any task demanding superior control and a smooth finish

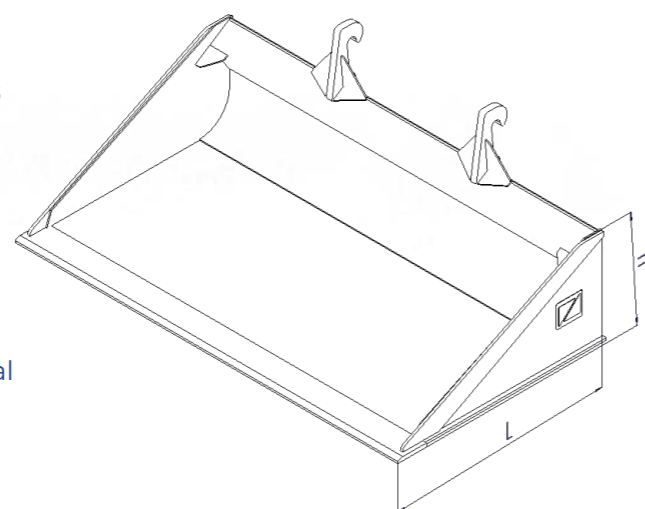

Transform your loader into a grading powerhouse with the Front Leveling Bucket. This attachment delivers exceptional performance for fine grading, backfilling, and material leveling tasks. The optimized design ensures superior control and efficient material handling, maximizing your productivity on any project requiring a smooth, even finish.

Upgrade your loader's capabilities and conquer grading challenges with the Front Leveling Bucket. **Contact us today to explore the perfect fit for your loader model!**

Model	Machine class [t]	Width [mm]	Weight [kg]	Capacity [dm ³]	Adapter	Length [mm]	Height [mm]
FLB-180	2 - 4	1800	180	540	L20	1000	500
FLB-200	4 - 6	2000	330	850	L30	1160	550
FLB-220	6 - 9	2200	370	960	L40	1260	650
FLB-240	9 - 12	2400	420	1150	L60	1260	650
FLB-260	12 - 14	2600	760	1800	L60	1460	750
FLB-280	14 - 17	2800	820	1950	L90	1560	800
FLB-300	17 - 20	3000	1120	2200	L120	1750	850



Hydro-Instal T.Sieruta B.Sieruta sp.j.
ul. Bohaterów Westerplatte 11
07-410 Ostrołęka
Poland
EU VAT ID: PL7581556948



+48 505 778 308

info@sieruta.com

sieruta.com